

# High Efficiency 12 mil Infrared Thinfilm LED (850 nm) Draft Version alpha.0

## F3553A

### Features

- High efficiency due to new Thinfilm concept
- Lambertian Emission pattern
- Polarity: n-side up
- Wavelength (typ.): 850 nm
- Technology: AlGaAs Thinfilm
- ESD withstand voltage: up to 2 kV acc. to ANSI/ ESDA/ JEDEC JS-001 - HBM

### Applications

- Infrared illumination
- Illumination for cameras
- Data Communication

### Safety advice

Depending on the mode of operation, these devices emit highly concentrated non visible infrared light which can be hazardous to the human eye. Products which incorporate these devices have to follow the safety precautions given in IEC 60825-1 and IEC 62471.

**Here you can find important REACH information of OSRAM Opto Semiconductors' products:**

[http://www.osram-os.com/osram\\_os/EN/Products/REACH](http://www.osram-os.com/osram_os/EN/Products/REACH)

Please also note the special information in the section „Handling and storage conditions“ on page 6.

Type	Ordering Code	Description
F3553A	on request	12 mil high efficiency Thinfilm chip, 840 - 860 nm, > 35mW

**Electrical values**<sup>1)</sup> ( $T_A = 25\text{ °C}$ , correlated to TO18 package)

Parameter	Symbol	Value <sup>2)</sup>			Unit
		min.	typ.	max.	
Centroid wavelength $I_F = 100\text{ mA}$ , $t_p = 20\text{ms}$	$\lambda_{\text{centroid}}$	840		860	nm
Reverse current not designed for reverse operation	$I_R$				$\mu\text{A}$
Forward voltage $I_F = 100\text{ mA}$ , $t_p = 20\text{ ms}$	$V_F$		1.7	2.0	V
Radiant power $I_F = 100\text{ mA}$ , $t_p = 20\text{ ms}$	$\Phi_e$	35	55		mW
Switching times, $\Phi_E$ from 10% to 90% and from 90% to 10%, $I_F = 100\text{ mA}$ , $R_L = 50\ \Omega$ .	$t_r, t_f$		12		ns
Temperature Coefficient of $\Phi_E$ <sup>3)</sup> $I_F = 100\text{ mA}$	$TC_I$		-0.3		%/K
Temperature Coefficient of $V_F$ <sup>3)</sup> $I_F = 100\text{ mA}$	$TC_V$		-0.6		mV/K
Temperature Coefficient of $\lambda$ <sup>3)</sup> $I_F = 100\text{ mA}$	$TC_\lambda$		+0.3		nm/K

<sup>1)</sup> Measurement limits describe actual settings and do not include measurement uncertainties. Each wafer and fragment of a wafer is subject to final testing. The wafer or its pieces are individually attached on foils (rings). All el. values are referenced to the vendor's measurement system (correlation to customer product(s) is required). Measurement uncertainty +/-15% for brightness, +/- 1nm for wavelength and +/- 0.1V for voltage.

<sup>2)</sup> Due to the special conditions of the manufacturing processes of LED, the typical data or calculated correlations of technical parameters can only reflect statistical figures. These do not necessarily correspond to the actual parameters of each single product, which could differ from the typical data and calculated correlations or the typical characteristic line. If requested, e.g. because of technical improvements, these typ. data will be changed without any further notice.

<sup>3)</sup> The values given represent the chip in an OSRAM Opto Semiconductor's Power TOPLED<sup>®</sup> package. Values may be different in other packages.

**Maximum Ratings<sup>1)</sup>**

Parameter	Symbol	Value	Unit
Maximum operating temperature range	$T_{op}$	-40...+100	°C
Maximum reverse voltage ( $T_A = 25^\circ\text{C}$ )	$V_R$	5	V
Maximum forward current ( $T_A = 25^\circ\text{C}$ )	$I_F$	100	mA
Maximum surge Current ( $T_A = 25^\circ\text{C}$ ) $t_p = 200 \mu\text{s}$ , $D = 0$	$I_{peak}$	1	A
Maximum junction temperature	$T_j$	125	°C

<sup>1)</sup> Maximum ratings are strongly package dependent and may differ between different packages. The values given represent the chip in an OSRAM Opto Semiconductor's Power TOPLED<sup>®</sup> package.

**Mechanical values**

Parameter	Symbol	Value <sup>1)</sup>			Unit
		min.	typ.	max.	
Length of chip edge (x-direction)	$L_x$	0.293	0.313	0.333	mm
Length of chip edge (y-direction)	$L_y$	0.293	0.313	0.333	mm
Diameter of the wafer	$D$		100		mm
Die height	$H$	120	150	180	$\mu\text{m}$
Diameter of bondpad	d	80	90	100	$\mu\text{m}$

**Additional information**

Metallization frontside	Gold
Metallization backside	Gold
Die bonding	Epoxy bonding

<sup>1)</sup> Due to the special conditions of the manufacturing processes of LED, the typical data or calculated correlations of technical parameters can only reflect statistical figures. These do not necessarily correspond to the actual parameters of each single product, which could differ from the typical data and calculated correlations or the typical characteristic line. If requested, e.g. because of technical improvements, these typ. data will be changed without any further notice

**Forward current<sup>1)</sup>**

$I_F = f(V_F), T_A = 25\text{ °C}, \text{Single pulse}, t_p = 100\ \mu\text{s}$

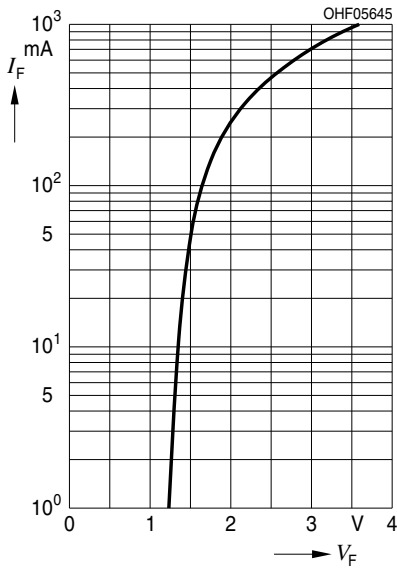

**Relative radiant intensity<sup>1)</sup>**

$I_e/I_{e(100\text{ mA})} = f(I_F), T_A = 25\text{ °C}, \text{Single pulse}, t_p = 100\ \mu\text{s}$

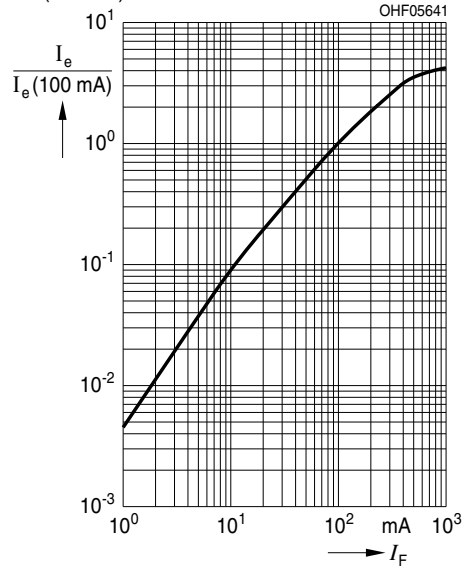

**Relative spectral emission<sup>1)</sup>**

$I_{rel} = f(\lambda); I_F = 100\text{ mA}$

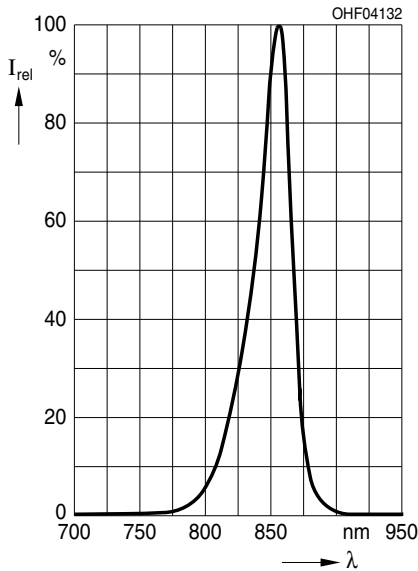

**Permissible pulse handling capability<sup>1)</sup>**

Duty cycle  $D = \text{parameter}, T_A = 25\text{ °C}$

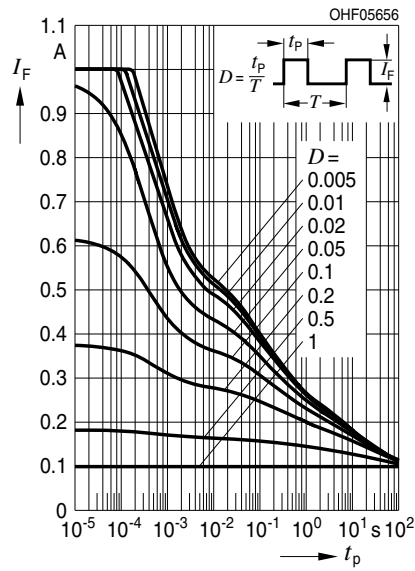

<sup>1)</sup> Due to the special conditions of the manufacturing processes of LED, the typical data or calculated correlations of technical parameters can only reflect statistical figures. These do not necessarily correspond to the actual parameters of each single product, which could differ from the typical data and calculated correlations or the typical characteristic line. If requested, e.g. because of technical improvements, these typ. data will be changed without any further notice. Given values are package dependent.. The values represent the chip in an OSRAM Opto Semiconductor's Power TOPLED® package.

## Chip Outlines

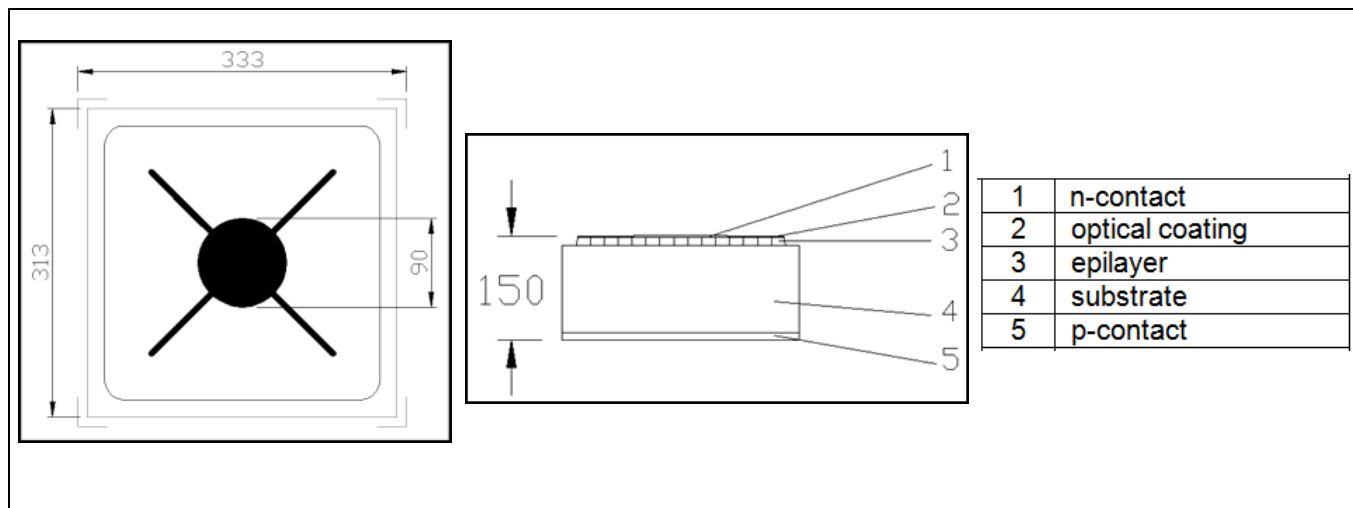

Dimensions are specified as typical<sup>1)</sup> values as follows: μm.

Published by OSRAM Opto Semiconductors GmbH

Leibnizstrasse 4, D-93055 Regensburg

© All Rights Reserved.

### Disclaimer

OSRAM OS assumes no liability whatsoever for any use of this document or its content by recipient including, but not limited to, for any design in activities based on this preliminary draft version. OSRAM OS may e.g. decide at its sole discretion to stop developing and/or finalising the underlying design at any time.

### Attention please!

The information generally describes the type of component and shall not be considered as assured characteristics or detailed specification.

Terms of delivery and rights to change design reserved. Due to technical requirements components may contain dangerous substances. For information on the types in question please contact our sales organization.

### Handling and Storage Conditions:

Storage time for wafers in sealed condition shall not exceed 6 months (storage ambient conditions:  $T_a=15...30^{\circ}\text{C}$ ; relative humidity:  $< 60\%$ ). The hermetically sealed shipment lot shall be opened under temperature and moisture controlled cleanroom environment only. Customer has to follow the according rules for disposition of material that can be hazardous for humans and environment.

Chips are placed on a blue foil, which may contain the following substance in a concentration of circ.18% wt:

Bis (2-ethyl(hexyl)phthalate) (DEHP) [CAS #: 117-81-7; EC # 204-211-0].

Dice have to be handled ESD sensitive.

### Packing

Chips are placed on a blue foil, with a typical size of 18x18cm<sup>2</sup>.

For shipment the wafers of a shipment lot are arranged to stacks. The top and bottom of the stack is covered by a hard black cover to protect the top and bottom wafer from damage. The whole package sealed in a plastic bag for storage and shipment.

Please use the recycling operators known to you. We can also help you – get in touch with your nearest sales office.

By agreement we will take packing material back, if it is sorted. You will have to bear the costs of transport. For packing material that is returned to us unsorted or which we are not obliged to accept, we shall have to invoice you for any costs incurred.

**Label and shipping documents**

Each wafer is identified with a sticker, which is attached to the back of each wafer. The label shows chip type, wafer number, quantity, binning and the minimum, average and maximum values of voltage, radiant power and wavelength. Each wafer shipment includes an additional document, which summarizes the content.

**Design objectives**

## a) workability

The chip design was developed and released based on the vendor's standard assembly procedures and packaging. Bond strength properties are in accordance to MIL-STD-750D, method 2037. Whether the chip fits to the customer's product(s) with its according die and wire bond procedures and packaging must be evaluated by the customer himself. If workability problems arise after this release a mutually conducted problem solving procedure has to be set up, if the chips are suspected of contributing to the problems

## b) chip characteristics

The chips are produced by the vendor with best effort, but on chip level a subset of the chip characteristics can be determined only. Performance of the chip in the customer's product(s) can only be determined by the customer himself.

**Returns/Complaints**

To return material because of technical or logistical reasons a RMA-number is necessary. Samples for analysis purposes can be send to OSRAM OS without credit.

**Shipping Conditions:**

If not otherwise arranged, the "General Conditions for the supply of products and services of the electrical and electronics industry" apply for any shipment. If these documents are not familiar to you, please request them at our nearest sales office.

**Components used in life-support devices or systems must be expressly authorized by us for such purpose!**

Critical components<sup>2)</sup>, may only be used in life-support devices or systems<sup>3)</sup> with the express written approval of OSRAM OS..

<sup>1)</sup> Typical (referred to as typ.) data are defined as long-term production mean values and are only given for information. This is not a specified value.

<sup>2)</sup> A critical component is a component used in a life-support device or system whose failure can reasonably be expected to cause the failure of that life-support device or system, or to affect its safety or effectiveness of that device or system.

<sup>3)</sup> Life support devices or systems are intended (a) to be implanted in the human body, or (b) to support and/or maintain and sustain human life. If they fail, it is reasonable to assume that the health of the user may be endangered.

EU RoHS and China RoHS compliant product



此产品符合欧盟 RoHS 指令的要求；

按照中国的相关法规和标准，不含有毒有害物质或元素。